

Agilent AEDL Series Optical Linear Incremental Encoder

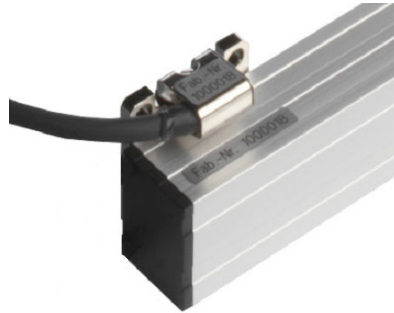

Description

The AEDL Series linear encoders use high technology transmissive optical encoding technique to detect linear motion. There is no mechanical contact between the scanning head and the linear scale, thus eliminating error due to frictions and alignment errors.

Basically, the encoder consists of a precision linear glass scale and a scanning head, which translate the linear position into analog and digital electrical signals. The encoder can be easily aligned and installed using the provided spacer-clip and the self-adhesive mounting feature. Using Agilent's Quick Stick™ method, the encoder profile can be easily adjusted while the system is aligned to the machine system. The Quick Stick™ method provides spacing foam that prevents the encoder profile from sticking to the machine base until the alignment has been performed. A pair of L-pins (setting pins) ensured that the scanning head is fixed at a nominal position while the linear encoder is aligned and mounted to the machine system.

With state of the art technologies, Agilent's linear encoders provide an ideal feedback control to high precision motion systems. The linear encoders are available in two colors, silver or black anodized.

Applications

The AEDL Series linear encoder provides linear motion detection, delivering an accurate and insensitive closed-loop control solution. Typical applications:

- XY table positioning
- high precision machines
- industrial plotter
- high-accuracy measurements
- linear motors
- robotics
- electronics assembly and inspection

Note: Agilent Technologies encoders are not recommended for use in safety critical applications, e.g. life support systems and critical care medical equipment. Please contact sales representative if more clarification is needed.

Features

- Insensitive to dirt/contamination
- Large mounting tolerance
- Analog or digital output signals
- Self-adhesive mounting profile
- Simple and easy assembly
- 5 – 2200 mm measuring length
- Traversing speed of up to 16 m/s
- 0.05 μm^* , 0.1 μm^* , 0.5 μm , 1 μm , 5 μm and 10 μm resolutions
- 40 μm grating period (pitch)
- $\pm 3 \mu\text{m}$ or $\pm 5 \mu\text{m}$ (per meter) accuracy class
- 0 °C to +55 °C temperature range
- Single 5V supply
- Up to 3 m cable length

ESD WARNING: NORMAL HANDLING PRECAUTIONS SHOULD BE TAKEN TO AVOID STATIC DISCHARGE.



Agilent Technologies

Theory of Operation

Agilent Technologies utilizes an ultra collimated LED as the light source for the AEDL linear encoders, where very high modulation can be achieved. A 22-element photodiode array in the scanning head detects the modulated light. A high technology signal-conditioning IC is integrated inside the scanning head. The IC performs real time phase, amplitude and offset signal monitoring, which will correct any deviation from the expected mathematical signal that is caused by environmental influence. Consequently, a high purity sinusoidal signal is available for interpolation process, which is performed in the same IC. A world-class high precision measurement system is thus achieved through Agilent's linear encoders.

Output incremental signal can be specified as either digital (RS422) or 1 Vpp analog sinusoidal when ordering. Signals of Channel A and Channel B are 90° phase-shifted. Index marks are periodically spaced at a distance of 50 mm, or distance coded at 500 x pitch size*. Fault detection signal is activated when improper operation occurs, such as power cutoff, loss of light source or heavy contamination. This signal can be used to shut down machine operation safely, when a failure occurs.

Definitions

Resolution: Smallest movement detectable by the encoder. It is normally expressed in units of distance (e.g. 0.5 μm or 100nm).

Accuracy: A measure of how close the output is to where it should be. It is usually expressed in units of distance over the scale length (e.g. +/- 3 μm per meter) or a percent of nominal resolution.

Interpolation: An electronic technique for increasing the resolution from the optical cycles on the linear scale to a higher number of quadrature square waves per unit length. These square waves can then be further quadrature decoded.

Quadrature: This term refers to the 90-electrical-degree (1/4 of a cycle) phase relationship between the A and B channels of incremental encoder output.

Quadrature Decode: Also known as 4X Decode, it refers to the common practice of counting all 4 quadrature states (or square wave transitions) per cycle of quadrature square waves. Thus, a linear encoder with a cycle width of 40 μm , for example, has a resolution of 10 μm .

Pitch: Also known as grating or optical period, it refers to the distance for a single window-bar pair on the linear scale.

Measurement Length (ML): The effective measurement length that the encoder system can be used for.

Index Signal: A once-per-scale output or multiple outputs at certain fixed locations. It is used to establish a reference to a known home or starting position. Also known as reference mark, home, or Z.

* Note: 0.05 μm and 0.1 μm are future options, which are not yet available. The resolutions stated are after interpolation and users' quadrature decoding. Distance-coded version will be available as a future option.

Outline Drawing

	Description
A	Start of measuring length
B	Distance between the mounting screw holes
C	Cable diameter
D	Overall length of measuring system (ML + 34 mm)
E	Mounting surface with high strength adhesive tape type TESA 4965
F	Output signal (RS422A digital or analog 1 Vpp)
G	Initial position of scanning head when ready for installation (available on the opposite side upon request)
H	Mounting surface to machine parts

Tape Mounting Version

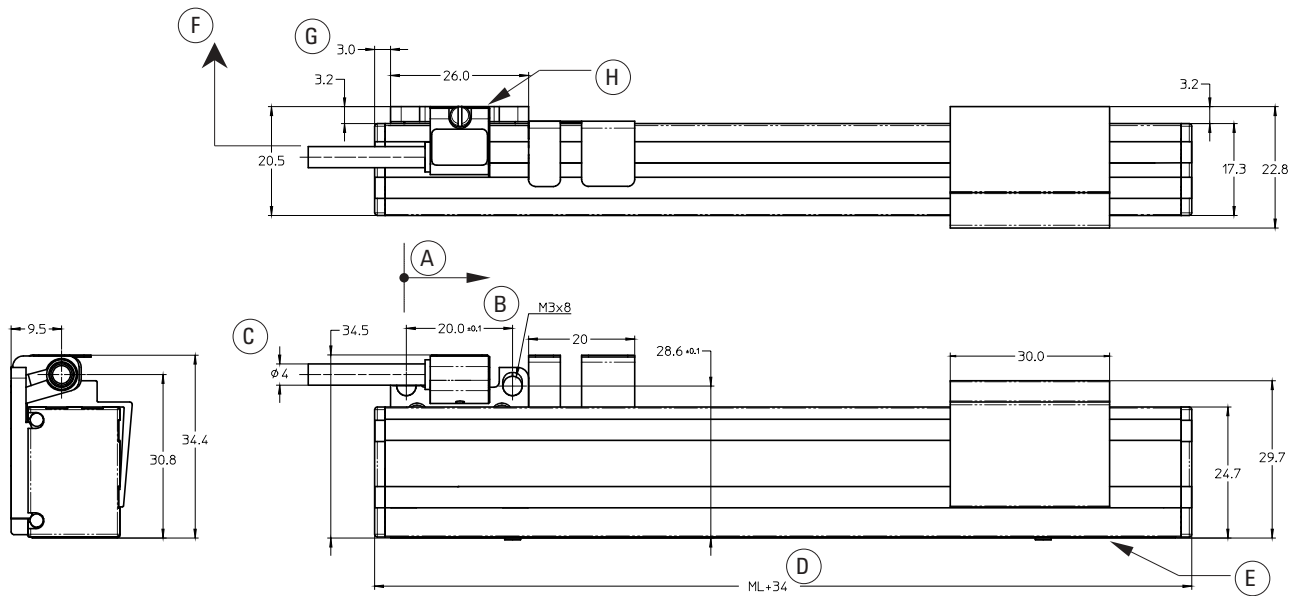

Connector Pin Configuration

Four options of connector types are available, namely the 12-pin heavy-duty industrial, 15-pin D-Sub, 9-pin D-Sub or strand wire options. Table 1 shows the pins configuration and cable color for the respective connector types. There are also options of either left or right cable exit for the cable.

12-pin Round Connector

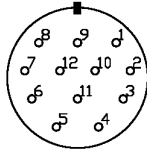

PIN	Analog (1 V _{pp})	Digital RS 422	Cable color
1	Cosine negative, U ₂₋	Channel B negative, Z ₂₋	Pink
2	Power supply, +5V	Power supply, +5V	White/Green
3	Index Positive, U ₀₊	Index positive, Z ₀₊	Red
4	Index negative, U ₀₋	Index negative, Z ₀₋	Black
5	Sine positive, U ₁₊	Channel A positive, Z ₁₊	Brown
6	Sine negative, U ₁₋	Channel A negative, Z ₁₋	Green
7	NC	Error, active low	Purple
8	Cosine positive, U ₂₊	Channel B positive, Z ₂₊	Grey
9	NC	Error, active high	Yellow
10	0V	0V	Brown/Green
11	0V	0V	-
12	+5V	+5V	-
Shell	Shield	Shield	-

15-pin D-Sub Connector (male)

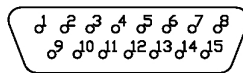

PIN	Analog (1 V _{pp})	Digital RS 422	Cable color
1	NC	NC	-
2	NC	NC	-
3	NC	Error , active low	Purple
4	Index negative, U ₀₋	Index negative, Z ₀₋	Black
5	Cosine negative, U ₂₋	Channel B negative, Z ₂₋	Pink
6	Sine negative, U ₁₋	Channel A negative, Z ₁₋	Green
7	NC	NC	-
8	Power supply, +5V	Power supply, +5V	White/Green
9	0V	0V	Brown/Green
10	NC	Switch	White
11	NC	Error, active high	Yellow
12	Index Positive, U ₀₊	Index positive, Z ₀₊	Red
13	Cosine positive, U ₂₊	Channel B positive, Z ₂₊	Grey
14	Sine positive, U ₁₊	Channel A positive, Z ₁₊	Brown
15	NC	NC	Blue
Shell	Shield	Shield	-

9-pin D-Sub Connector (male)

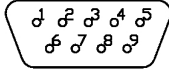

PIN	Option analog (1 V _{PP})	Option digital RS 422	Cable color
1	Sine negative, U ₁₋	Channel A negative, Z ₁₋	Green
2	0V	0V	Brown/Green
3	Cosine negative, U ₂₋	Channel B negative, Z ₂₋	Pink
4	NC	Error, active low	Purple
5	Index negative, U ₀₋	Index negative, Z ₀₋	Black
6	Sine positive, U ₁₊	Channel A positive, Z ₁₊	Brown
7	Power supply, +5V	Power supply, +5V	White/Green
8	Cosine positive, U ₂₊	Channel B positive, Z ₂₊	Grey
9	Index Positive, U ₀₊	Index positive, Z ₀₊	Red
Shell	Shield	Shield	-

Strand Wire Option

Cable color	Analog (1 V _{PP})	Digital RS 422
White/Green	Power supply, +5V	Power supply, +5V
Brown/Green	0V	0V
Red	Index Positive, U ₀₊	Index positive, Z ₀₊
Black	Index negative, U ₀₋	Index negative, Z ₀₋
Brown	Sine positive, U ₁₊	Channel A positive, Z ₁₊
Green	Sine negative, U ₁₋	Channel A negative, Z ₁₋
Grey	Cosine positive, U ₂₊	Channel B positive, Z ₂₊
Pink	Cosine negative, U ₂₋	Channel B negative, Z ₂₋
Purple	NC	Error, active low
Yellow	NC	Error, active high
White	NC	NC
Blue	NC	NC

Absolute Maximum Ratings

Storage temperature, T_S	-20 °C to + 70 °C
Operating temperature, T_A	0 °C to + 55 °C
Supply voltage, V_{CC}	4.5 V to 5.5V
Digital output voltage, V_O	-0.3V to $V_{CC} + 0.3V$

Recommended Operating Conditions

Storage temperature, T_S	-20 °C to + 70 °C
Operating temperature, T_A	0 °C to + 55 °C
Supply voltage, V_{CC}	5 V \pm 10 %
Analog output voltage, V_O	1 V \pm 0.2V at 120 Ω load
Digital output voltage, V_O	5 V \pm 10 % (RS422 compatible)
Output current per channel, I_{OUT}	15 mA, short circuit proof (analog) 40 mA, short circuit proof (digital)

Mechanical Data

Cross section (scanning head)	31.5 \times 20.2 mm (height \times width)
Mass (scanning head without cable)	15 g
Mass (overall system)	Mass of scanning head + 38 g/m
Maximum speed (0.5 μ m resolution)	3.0 m/s
(1.0 μ m resolution)	8.0 m/s
(5.0 and 10 μ m resolutions)	16.0 m/s
(1Vpp analog output)	16.0 m/s
Measuring scale material	Precision float glass
Thermal expansion coefficient (Glass scale)	7.8 $\times 10^{-6}$ K ⁻¹
(Scale with profile)	13.1 $\times 10^{-6}$ K ⁻¹
Extrusion profile material	Tempered precision Aluminum, anodized
Light source	Ultra collimated LED
Detector	22-element photodetectors array

Electrical Data

Maximum analog signal frequency (-3 dB)	400 kHz
Maximum power consumption with load (digital output)	200 mA
(analog output)	100 mA

Output Characteristics

Analog Output Signals (Sine U_1 , Cosine U_2 and Index U_0)

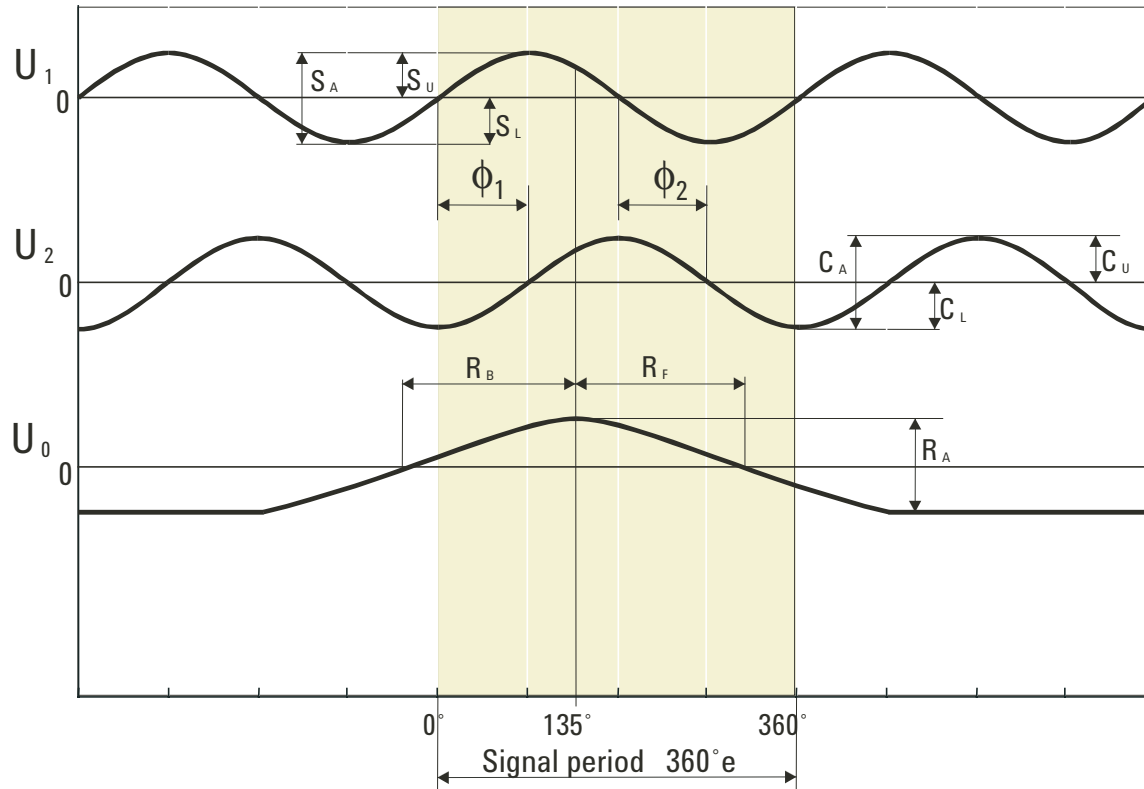

Figure 1. Output waveforms for analog output signals. Shown signals are measured in difference mode

Analog Signals

Sine U_1, Cosine U_2	
Peak-peak amplitude (S_A, C_A)	$1.0 \pm 0.2 \text{ V}$
Offset $ S_U - S_L / (2 \cdot S_A)$ or $ C_U - C_L / (2 \cdot C_A)$	≤ 0.05
Ratio S_A / C_A	1.0 ± 0.1
Phase $ \phi_1 + \phi_2 / 2$	$90^\circ \pm 10^\circ \text{ e}$
Index Channel U_0	
Signal amplitude R_A	$1.0 +1.6 \text{ V}$ -0.6
Index signal zero-crossover width R_B, R_F	$180^\circ \pm 90^\circ \text{ e}$

Digital Output Signal for Options N & P (Ch. A, Ch. B and Index)

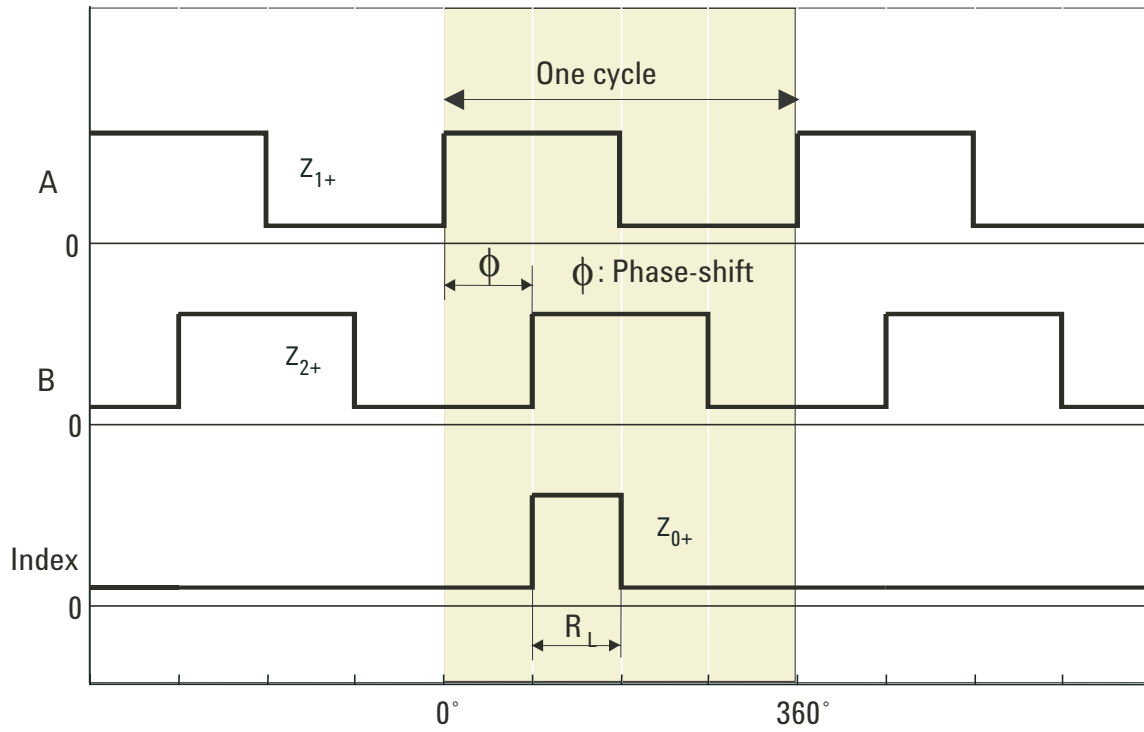

Figure 2. Digital output signals, with a quadrature phase-shift between Ch. A and Ch. B. The index pulse, which is active for $90^\circ e$, is gated with the incremental signals.

Digital Incremental Signals, RS422 compatible

Channel A & B	
Phase-shift	$90^\circ e$
Rise/Fall time	$\leq 40 \text{ ns}$
Index Channel	
Index pulse width, R_L	$90^\circ e$
Rise/Fall time	$\leq 40 \text{ ns}$

Interpolated Digital Output Signal (Ch. A, Ch. B, Index and Error)

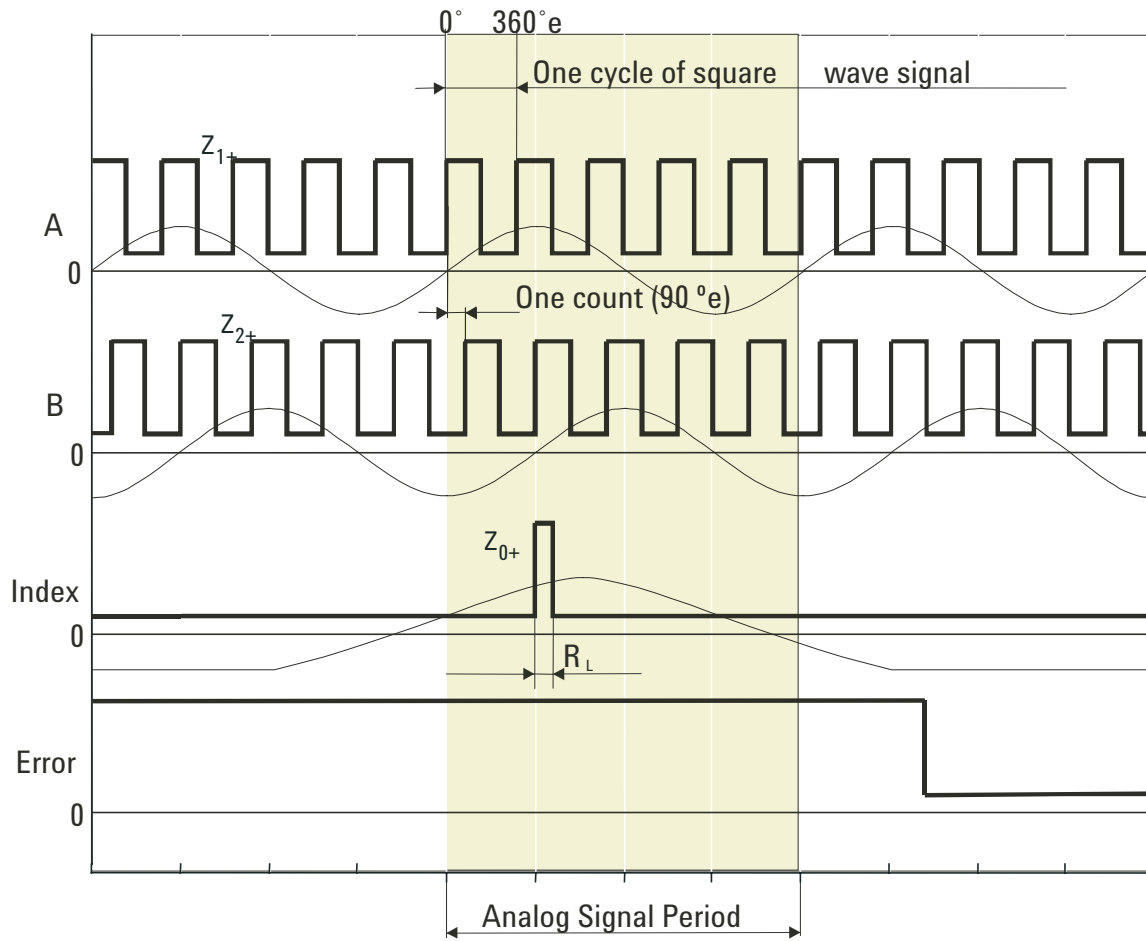

Figure 3. Interpolated digital output signals (A, B, and Index) and the error signal. The analog signal period corresponds to a 40- μ m distance.

Digital Incremental Signals, RS422 compatible

Channel A & B	
Phase-shift	$90^\circ e$
Rise/Fall time	≤ 40 ns
Index Channel	
Index pulse width, R_L	$90^\circ e$
Rise/Fall time	≤ 40 ns
Error Channel	
Error	Active high
Error	Active Low

Note:

Error signal is non-active for normal operation while an activated Error signal indicates that a fault is detected. Typical cause is due to power failure, loss of encoder light source or encoder signals are out of the limit.

Mechanical and Environmental Test

The encoders are tested according to the following international standards to ensure that they can withstand the most stringent environmental requirements.

Test Name	Reference	Conditions
Vibration (non-operating)	DIN IEC 68-2-6	50 Hz - 2 kHz, 10g/15g/30g, 10 cycles in 3 axes
		50 Hz - 2 kHz, 30g, 1 cycle (Glass scale only)
Shock (non-operating)	DIN IEC 68-2-27	10 g, 6 ms, 2000 shocks in 6 directions
		20 g, 11 ms, 1000 shocks in 6 directions
		50 g, 3 ms, 500 shocks in 6 directions
Electromagnetic Compatibility (EMC)	DIN EN61000-6-2	Industrial Environment Immunity Test
	DIN EN61000-4-2	Electrostatic Discharge (ESD): Discharge in air (± 8 kV) and contact discharge (± 4 kV)
	DIN EN61000-4-3	Electromagnetic RF-field in the range of 80 MHz to 1000 MHz, 80 % AM, 1 kHz
	DIN EN61000-4-4	Fast transient (bursts, ± 1 kV)
	DIN EN61000-4-6	RF-coupling into power line in the range of 0.15 to 80 MHz, 80 % AM, 1 kHz

Allowable Mounting and Machine Tool Tolerances

With reference to Figure 4, the total tolerances for the linear encoder are given as:

Error	Description	Tolerance
Δy	Total tolerance in the y-axis	$\pm 70 \mu\text{m}$
Δz	Total tolerance in the z-axis	$\pm 50 \mu\text{m}$
$\Delta\phi_X$	Roll angle, rotation about the x-axis	$\pm 50'$
$\Delta\phi_Y$	Pitch angle, rotation about the y-axis	$\pm 50'$
$\Delta\phi_Z$	Yaw angle, rotation about the z-axis	$\pm 25'$

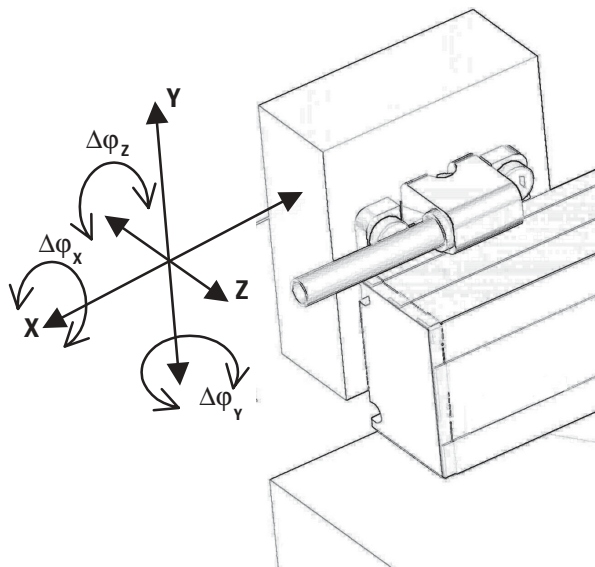

Figure 4. Definition of axes and rotational angles for the total allowable tolerance of the linear encoder

Recommended circuit

Digital RS422 interpolated output signals

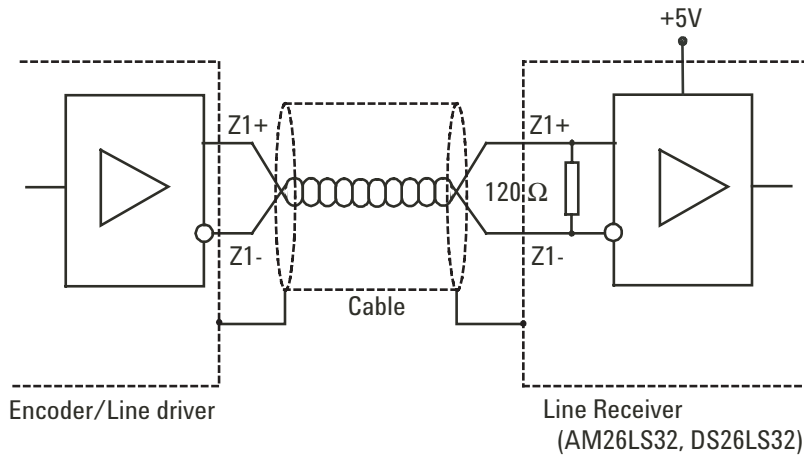

Figure 5. Recommended receiver circuits for the line driver digital output. The same circuit is applicable for Ch. A, Ch. B, Index, and Error channels.

Analog 1 V_{pp} Voltage signals

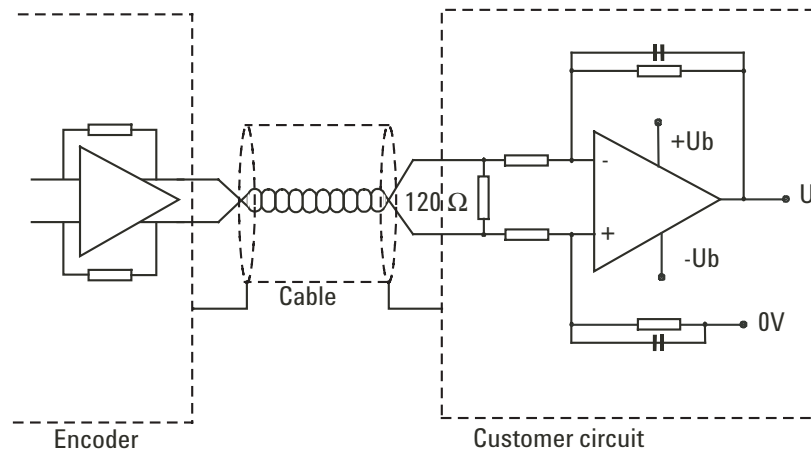

Figure 6. Recommended customer receiver circuit for analog output sine, cosine, and index signals.

Cable Characteristics

Diameter	4 mm
Cable structure	Twisted pairs with common shield
Number of cable cores	12 (1 pair of AWG 28 for power supply, and 5 pairs of AWG 30 for signal lines)

The cable complies with UL standard 20963. Operating conditions for the cable depend on the cable diameter and the cable configuration. The operating conditions are given in the following table:

	Fixed installation	Frequent flexing
Permissible bending radius, R	$R \geq 12 \text{ mm (0.48 in.)}$	$R \geq 40 \text{ mm (1.6 in.)}$

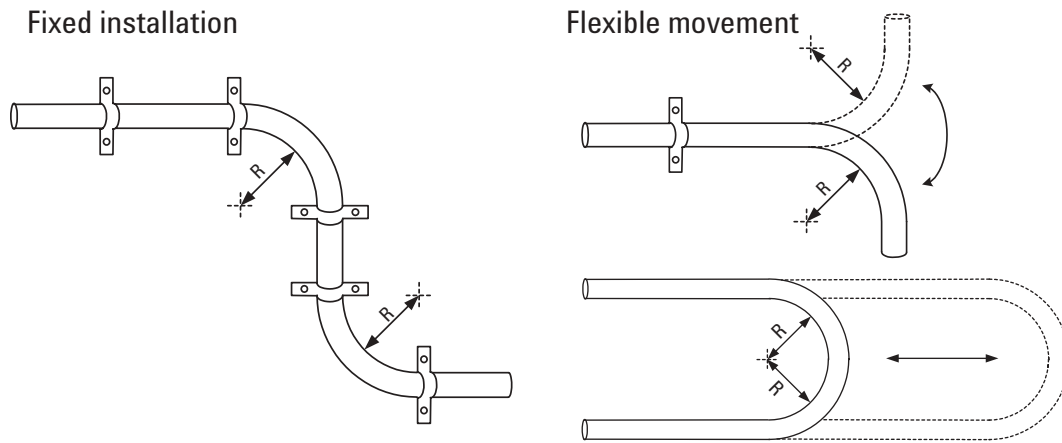
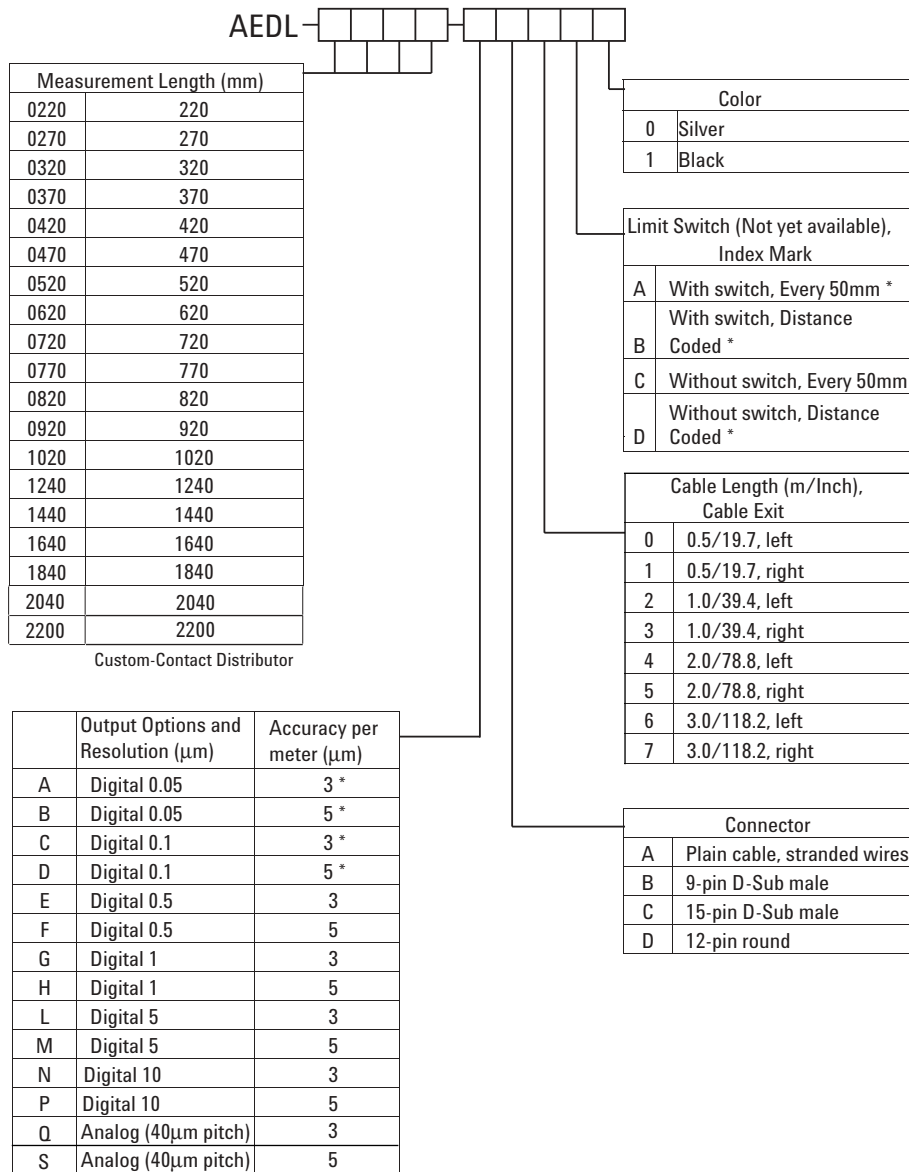

Figure 7. Cable bending radius for fixed and flexible installations

Ordering Information



Note: Options with * are not available yet

**www.agilent.com/
semiconductors**

For product information and a complete list of distributors, please go to our web site.

For technical assistance call:

Americas/Canada: +1 (800) 235-0312
or (408) 654-8675

Europe: +49 (0) 6441 92460

China: 10800 650 0017

Hong Kong: (+65) 6756 2394

India, Australia, New Zealand: (+65) 6755 1939

Japan: (+81 3) 3335-8152(Domestic/International), or 0120-61-1280(Domestic Only)

Korea: (+65) 6755 1989

Singapore, Malaysia, Vietnam, Thailand, Philippines, Indonesia: (+65) 6755 2044

Taiwan: (+65) 6755 1843

Data subject to change.

Copyright © 2005 Agilent Technologies, Inc.

March 3, 2005

5989-2553EN



Agilent Technologies